



FAIRVIEW™

DEFINING ARCHITECTURE SINCE 1993



vitradual™

PRODUCT INFORMATION

NON-COMBUSTIBLE CASSETTE CLADDING / MANUFACTURED BY FAIRVIEW

ABOUT VITRADUAL

Vitradual is a 3mm solid aluminium façade cladding system that forms part of Fairview's range of NCC compliant, deemed non-combustible cladding solutions. It's suitable for Type A and B constructions and is a high impact resistant, solid panel which can be fabricated, curved and rolled.

The pre-finished large format cladding panels feature the same PVDF coating system as Vitracore G2 and is well recognised for its superior quality and design integrity. Vitradual provides an almost unlimited range of colours and finishes, including the option of customisable graphic panels through the Fairview VitraArt option.

The panels are tough, dependable and reliable, yet beautiful, contemporary and functional in their simplicity. Vitradual is an enduring building material that is infinitely recyclable to be repurposed into endless future possibilities.

With over 800,000M² of Vitradual installed across Australia, Vitradual offers reliable durability and functionality that is proven through the test of time.

KEY FEATURES

Vitradual's versatility is achieved due to the combination of high-quality considerations and industry leading components. Vitradual is one of the few large format cladding panels that are deemed non-combustible when tested to AS1530.1 and AS1530.3.

Material	Pre-finished solid aluminium panel.
Finish	Vitradual uses only the highly recognised PVDF or FEVE paints known for their high durability, providing the optimum resistance to weather and industrial pollution.
Fixing System	A cassette style concealed fixing system allowing for a sleek, modern and flat finish.
Application	Type A and B constructions where non-combustible materials are required such as mixed-use developments, residential construction and large-scale government infrastructure projects, like hospitals.
Warranty	15-year warranty, subject to standard terms and conditions.



PANEL SPECIFICATION

Vitradual is a 3mm solid aluminium product. The panels weigh in at 8.1 kilograms per square metre, making the product ideal for large infrastructure developments such as schools and hospitals.

Vitradual is available in a variety of width and length combinations to suit almost any project and custom sizes are also available on request.

TYPICAL COMPOSITION

1. Protective film
2. PVDF coating system
3. 3mm Aluminium
4. Protective rear coating

The material is rigid, resistant to blows, breakage and pressure and has high bending, buckling and breaking strengths.

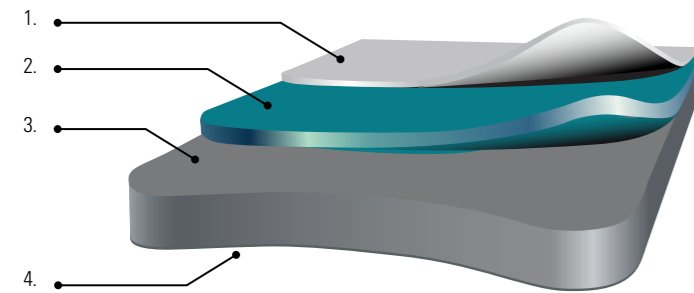

Dimensions Thickness: 3mm

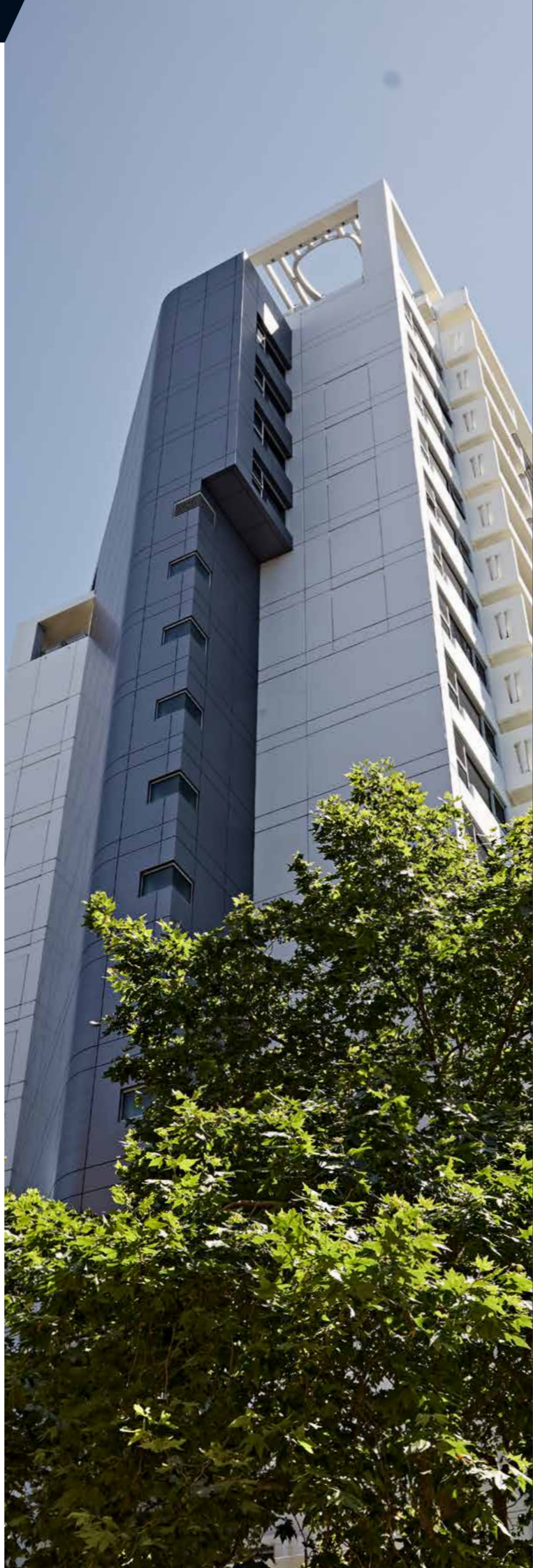

PANEL SIZES

Width	Length
1250/1500	2500
	3200
	4000

Custom sizes are available, please speak to the Fairview team





FINISH

Vitradual uses only the highly recognised PVDF or FEVE paints known for their excellent durability. These premium paints provide the ultimate resistance to weather and industrial pollution. Vitradual has an unlimited colour range, as we can match almost any finish and colour required.

Vitradual panels also come in a range of anodised finishes, offering both standard and customised colours and textures, including:

- SOLID COLOURS
- METALLIC
- WOODCREATE
- NATURALINE
- SPARKLING
- CHROMATIC
- AGED METAL

To view the full colour range please visit the Vitradual Colour Chart on our website www.fv.com.au.

The project featured below uses Vitradual in our striking Rust Patina finish, an aged metal aesthetic that brings a rich, weathered elegance and dynamic character to the building envelope. Vitradual is designed to give architects the flexibility to achieve their design intent, offering a wide range of finishes and customisation options to meet the demands of contemporary architecture.

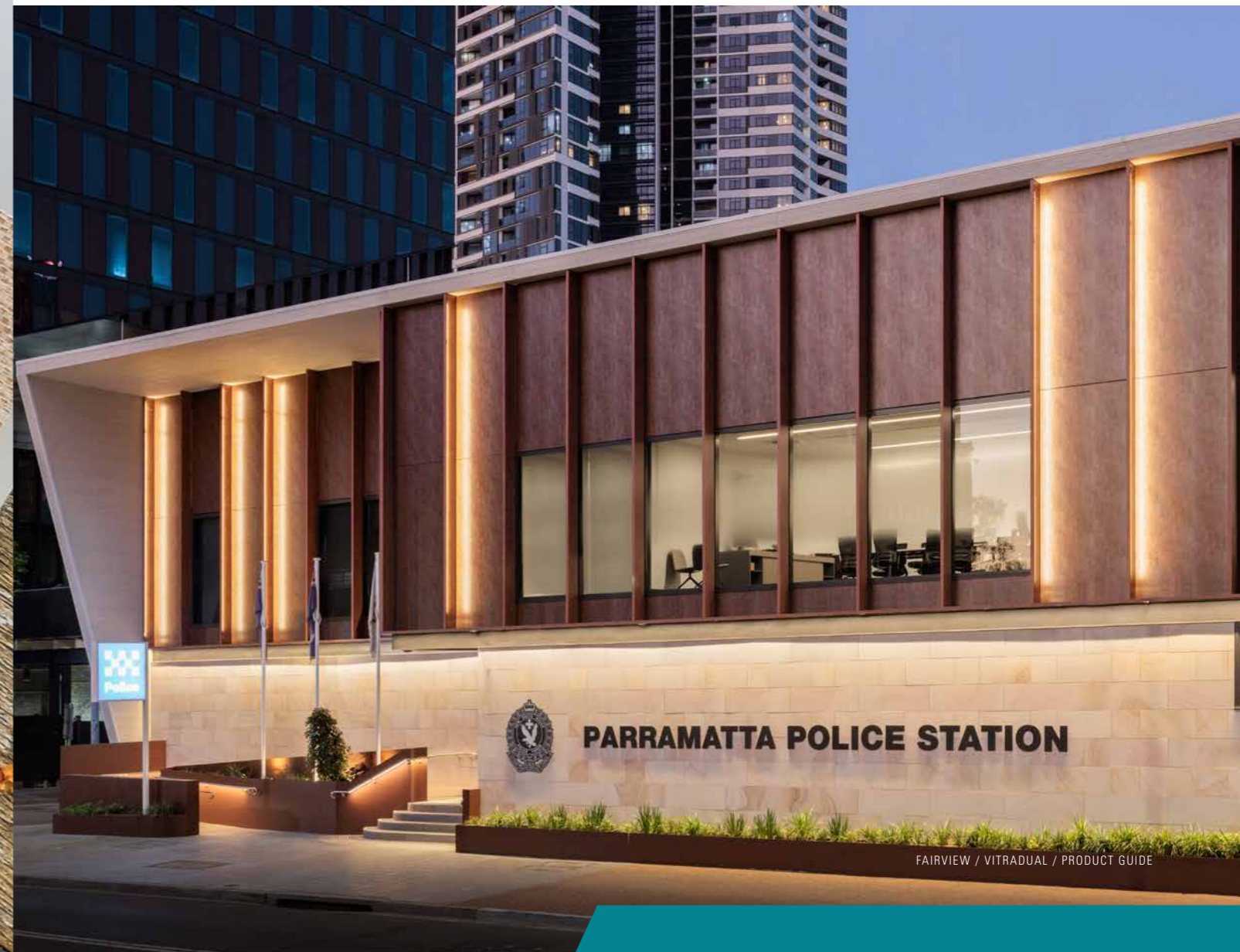

PARRAMATTA POLICE STATION

FIXING SYSTEM

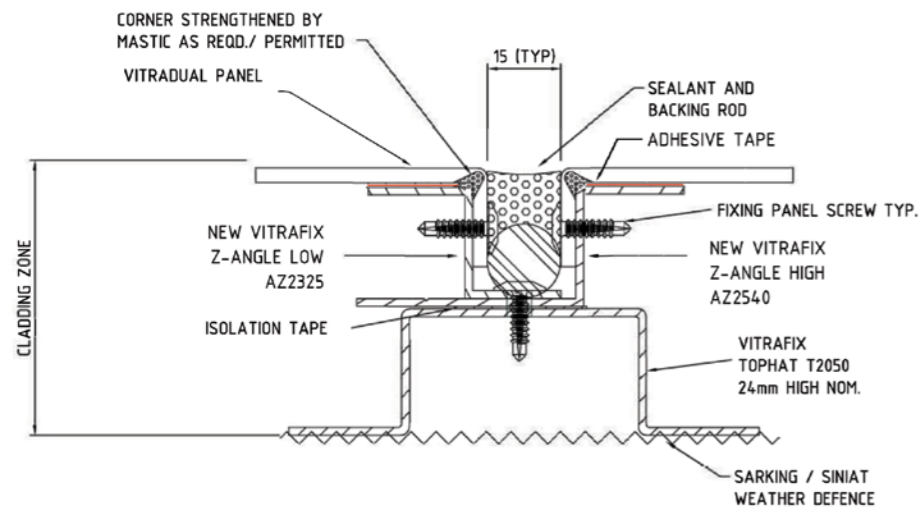

The above diagram is indicative only. For more information please refer to the Vitradual Technical Information.

WARRANTY

Vitradual is an incredibly durable material when used in the right application. Vitradual includes a 15-year warranty, subject to standard terms and conditions.

DISCLAIMER

While the information provided relating to Fairview Architectural products is true to the tests and measures available to us, the information provided in this article is general in nature only and does not constitute project-specific building, construction or fire-safety advice. Before acting on any information on this document, you should consider the appropriateness of the information in regard to your project parameters and requirements. Fairview products are deemed suitable or compliant after approval from building and construction professionals associated with specific projects and developments. If you'd like some further insight about this topic, contact Fairview on 1800 007 175 or email helpdesk@fv.com.au. We're here to see how we can help.



VITRAFIX ACCESSORIES

To complete the Vitradual system install, consult our full range of accessories, including:

- Z-Angles
- Top Hats
- Vapour Permeable Membranes
- Tapes
- Caulking
- Backing Rods

Fairview is passionate about the continual improvement of our range of products and accessories. As such, we have developed new Z-Angles that evolve and maximise the performance of façades resulting in more durable building designs.

The advantages of our new Z-Angles include:

1. More engagement under the panel – from 10mm to 25mm to strengthen the routed cassette return.
2. More space to fit adhesive tape or structural silicone.
3. Under NCC22, tapes are now permitted to be used on panels. The new design facilitates this new allowance to provide much stronger cassette folds.

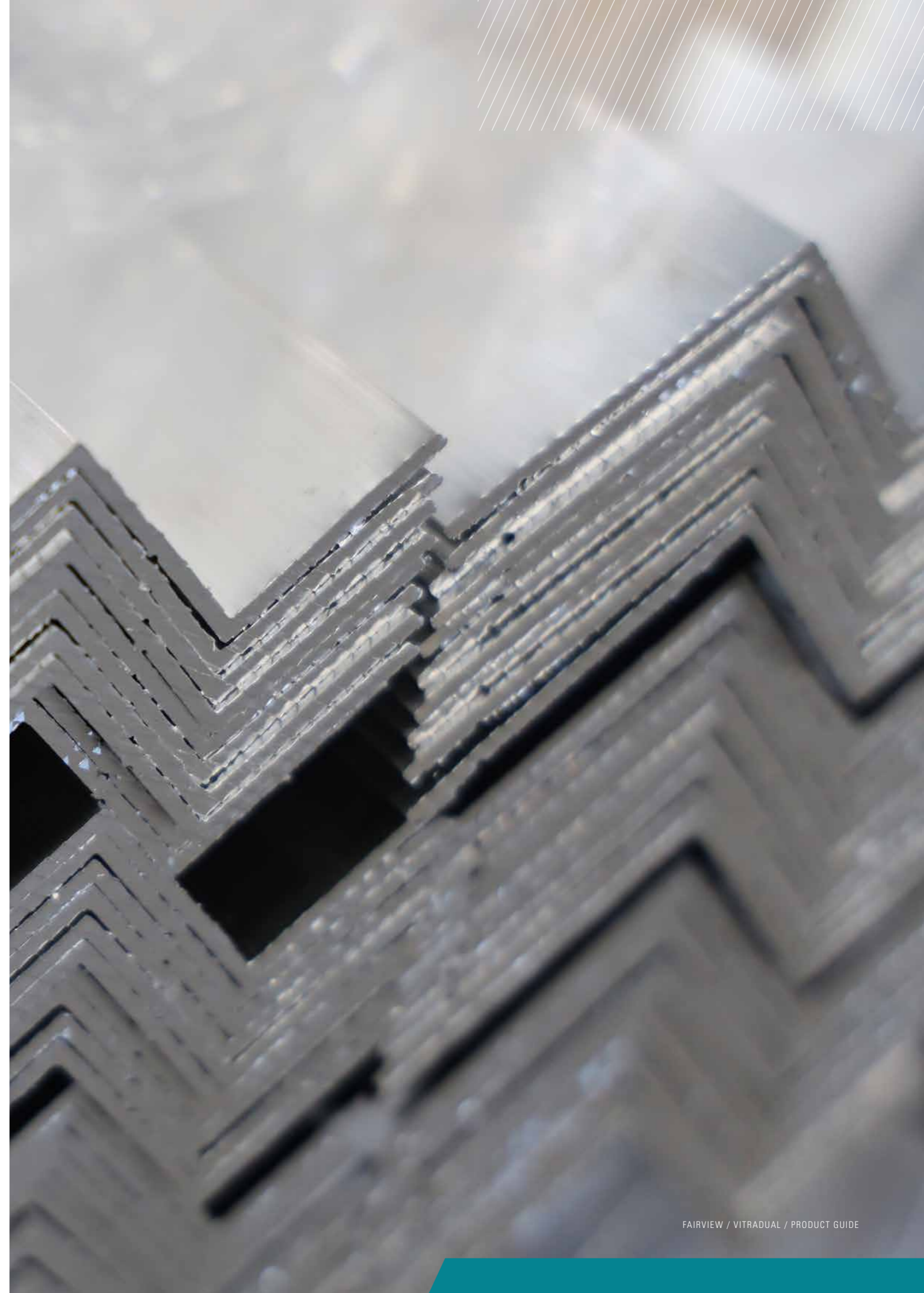
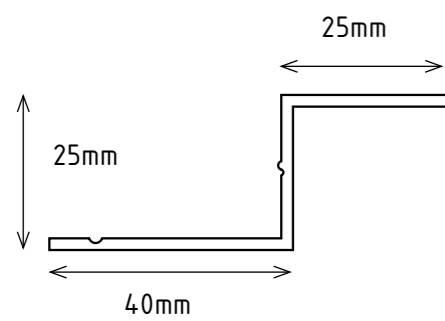
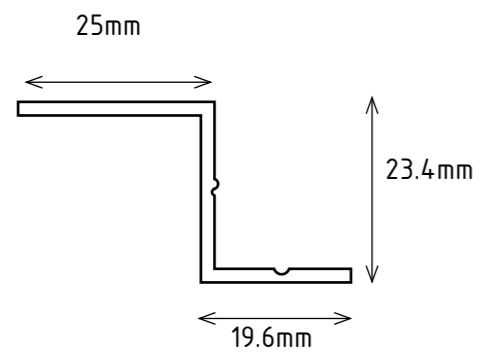



FAIRVIEW™

DEFINING ARCHITECTURE SINCE 1988



AUSTRALIA
NEW ZEALAND
UNITED KINGDOM

SALES ENQUIRIES 1800 007 175

HELPDESK@FV.COM.AU

FV.COM.AU

VITRADUAL / JUNE 2026