



FAIRVIEW™

DEFINING ARCHITECTURE SINCE 1988



solara™

ARCHITECTURAL SUNSCREENS / MANUFACTURED BY FAIRVIEW

INSTALLATION MANUAL

CONTENTS

About	3
Key Features	3
Solara Terracotta	4
Profiles	5
Installation Guide	6
Material Properties	7
Performance	7
Solara Aluminium	8
Profiles	9
Installation Detail	10
Accessories	11
Installation Guide	12
Coating Specifications	16
Material Properties	17
Performance	17
Structural Design & Specification Assessment	18
Warranty	27
Disclaimer	27

ABOUT SOLARA

Architectural battens bring rhythm, depth and shadow to a facade, elements that evolve throughout the day and subtly transform a building's character. Solara Architectural Sunscreens by Fairview delivers flexible, high-performance batten systems across two distinct material ranges, aluminium and terracotta. Each range offers its own aesthetic and material advantages, allowing designers to explore diverse expressions across a wide variety of architectural contexts.

Solara terracotta offers material richness through organic fired colours, glazes and textured finishes. From earthy to bespoke, the range supports both grounded and refined architectural outcomes while maintaining a sense of authenticity and timeless appeal.

Solara aluminium provides an expansive spectrum of colours and finishes, from virtually unlimited powder-coat selections to the refined metallic depth of anodised surfaces. EzyHD2 woodgrain coatings add the warmth and biophilic appeal of timber without the limitations of natural wood, delivering durability, consistency and low maintenance.

Solara battens support concealed or exposed fixing options and can be installed vertically or horizontally in continuous, spaced or patterned layouts. This flexibility gives designers precise control over shadow, scale and surface expression.

Designed to complement any facade system, Solara meets National Construction Code requirements and is backed by industry-leading warranties, delivering straightforward installation with enduring architectural impact.

KEY FEATURES



ALUMINIUM AND TERRACOTTA

A comprehensive batten offering featuring one of the broadest palettes and material selections on the market, supporting diverse architectural outcomes across both aluminium and terracotta.



EASY INSTALLATION & LOW MAINTENANCE

Solara battens can be cut and installed onsite using standard tools, reducing lead times and installation costs. Once installed, the system requires minimal maintenance while retaining its appearance and performance over time.



SEAMLESS FACADE INTEGRATION

Solara is the only batten system designed to integrate seamlessly within a complete Fairview facade specification. Solara can be colour and finish matched to the Fairview facade range including Stryum, Vitradual, Vitracore G2 and Clayton, enabling a cohesive, fully integrated facade specification through a single system.



ENERGY EFFICIENT

Solara architectural sunscreens help reduce heat gain and improve facade shading, supporting better thermal comfort and increased overall building energy efficiency.



SIMPLIFIED SPECIFICATION AND PROCUREMENT

One supplier, one order and one coordinated set of drawings reduces complexity and eliminates the need for additional supplier relationships, streamlining project delivery from specification through to installation.



EXPERT SUPPORT

Solara is designed to meet National Construction Code requirements and is supported by the same compliance rigour, engineering expertise and technical documentation as the broader Fairview facade range.

SOLARA TERRACOTTA

The typical composition of Solara terracotta architectural sunscreens incorporates a robust and straightforward assembly:

- Extruded terracotta batten
- Internal structural support profile
- End-fixing brackets and screws

Solara terracotta features a secure end-fixing design that simplifies installation, reducing on-site labour costs while delivering a clean, durable, and natural finish. The assembly typically involves securing the terracotta batten to the substructure using specialized brackets that insert into the ends of the batten profile, fastened with screws for a secure connection.

Offered in many different sizes and profiles, the system provides flexibility to achieve a wide range of design outcomes. Custom profiles are also available to meet specific project requirements.

Product	Terracotta batten system – available in various extruded profiles
Finish	Wide range of natural fired clay colours and glazed finishes
Fixing System	Pre-assembled terracotta batten system for straightforward installation
Application	Suitable for Type A, B, and C constructions where non-combustible materials are required, including mixed-use developments, residential projects and large-scale government or commercial buildings
Warranty	15-year warranty, subject to standard terms and conditions

PROFILES

SQUARE

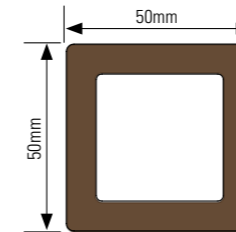

CIRCULAR

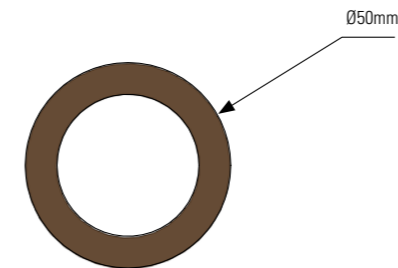

RECTANGULAR

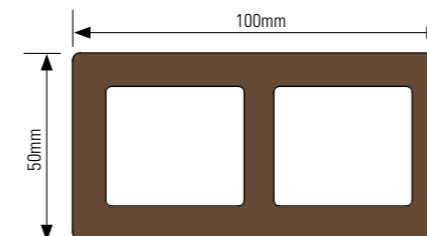

RECTANGULAR WIDE

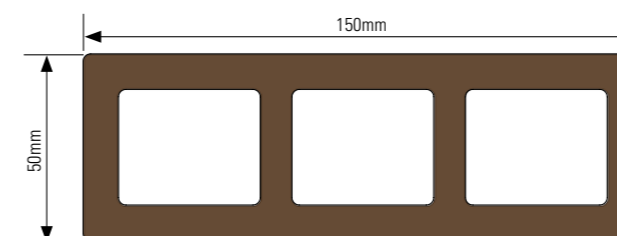

CAMBERED

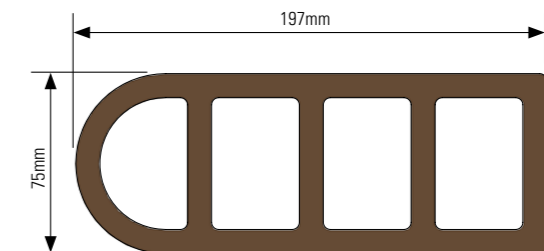

LOUVER

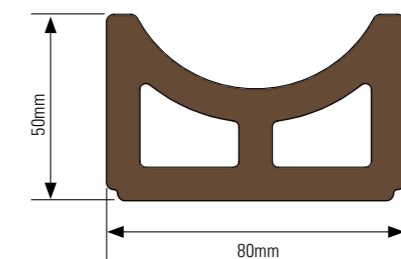

LAMERA

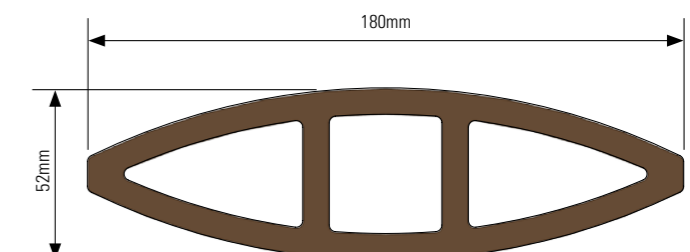

ARC

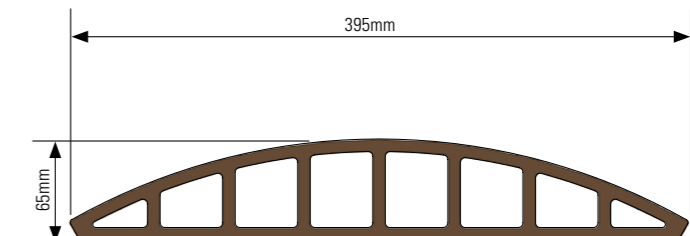

INSTALLATION GUIDE



SQUARE



CAMBERED



CIRCULAR



LOUVER

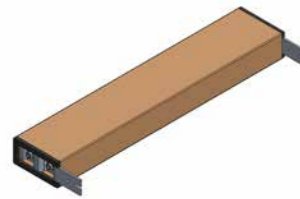

RECTANGULAR



LAMERA



RECTANGULAR WIDE



ARC

1. Position the preassembled batten to the supporting structure and fix it as required.

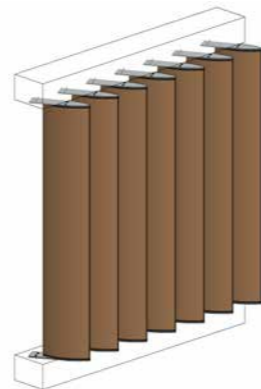
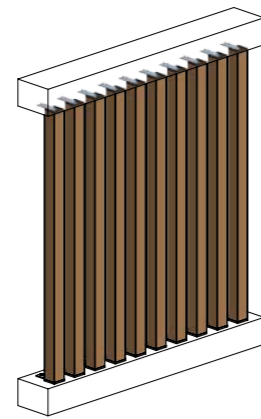
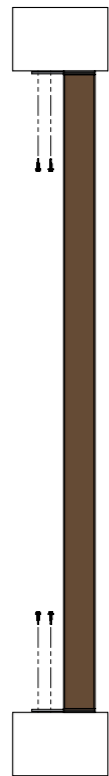
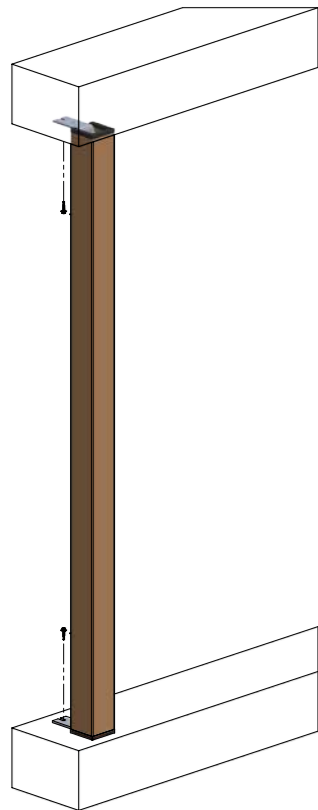

MATERIAL PROPERTIES

Solara terracotta battens are extruded ceramic facade products. Once extruded, the battens are fired in a kiln at approximately 1200 degrees Centigrade. This process permanently locks the shape and natural colour into the batten, ensuring its longevity and aesthetic integrity throughout the building's life. Solara terracotta battens are classified as non-combustible under section C2D10 (5)(G) of the National Construction Code, offering a safe and reliable facade solution.

The following technical data provides indicative material properties for Solara terracotta battens. These values are based on the inherent characteristics of high-quality kiln-fired terracotta and are generally consistent across similar extruded ceramic products manufactured using the same material composition and firing process. Certain performance values may vary depending on the batten profile geometry, manufacturing tolerances, support conditions, and production batch. Project-specific performance requirements should be verified against the latest product specifications and applicable testing data.

TECHNICAL DATA	TERRACOTTA BATTEN
Bibulous Rate	3.8%
Gravity Density	22.5kN/M3
Frost Resistance	No cracks or peeling after 100 freeze-thaw cycles
Elastic Modulus	40.7GPa
Fire Performance	A1
Linear Coefficient of Thermal Expansion	5.97 X 10 C

PERFORMANCE

FIRE	
Ignitability Index	0
Heat Evolved	0
Spread of Flame	0
Smoke Developed	0-1

SOLARA ALUMINIUM

The typical composition of Solara aluminium incorporates two elements:

- Two-Piece – Clip on Batten System
- Single Piece Box Extrusion System

Solara aluminium features a clip-on and solid box extrusion design that simplifies installation, reducing on-site labour costs while delivering a clean, durable finish.

Offered in many different sizes, the system provides flexibility to achieve a wide range of design outcomes. Solara aluminium battens are available in multiple lengths, with custom profiles and widths also available to meet specific project requirements.

Product	Aluminium batten system – available in clip-on and solid box extrusion profiles
Finish	Wide range of powder coat finishes, textured woodgrain finishes and authentic anodised finishes
Fixing System	Clip-on and screw fixing options for straightforward installation
Application	Suitable for Type A, B, and C constructions where non-combustible materials are required, including mixed-use developments, residential projects, and large-scale government or commercial buildings
Warranty	15-year warranty, subject to standard terms and conditions

PROFILES

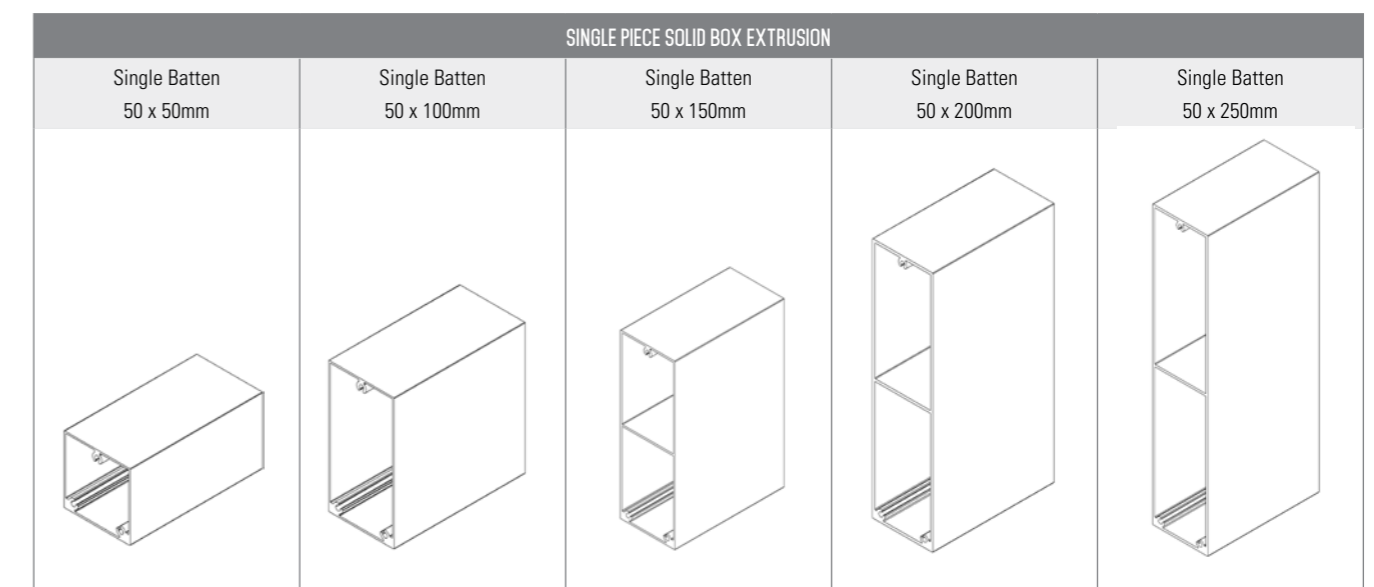
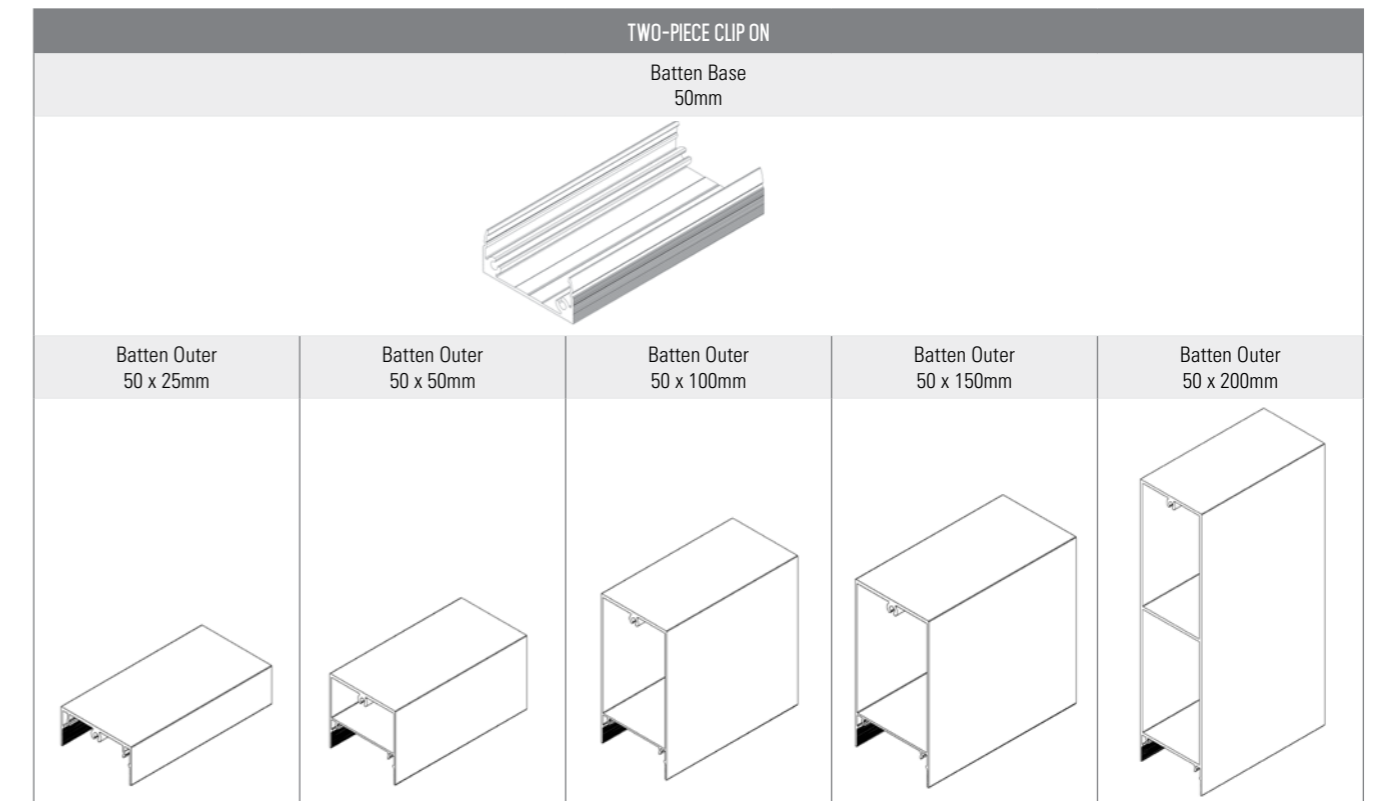





INSTALLATION DETAIL

INSTALLATION CONSIDERATIONS

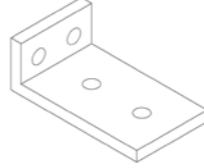
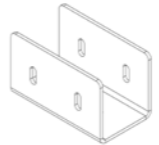
- As minor colour variation can occur between production lots, it is recommended the total material requirements for a project are placed in one order to ensure colour consistency.
- Where aluminium materials meet dissimilar metals, a proper insulator or caulking tape should be applied to insulate between dissimilar materials to avoid corrosive and electrolytic action.
- Please ensure Solara is installed as part of a compliant wall system, with all components complying with the Deemed-to-Satisfy provisions of the relevant NCC or approved as part of a performance solution.
- Solara aluminium will be installed with uncoated cut edges. Aluminium is extremely resistant to corrosion and within minutes of cutting the panel, a thin oxide layer will have formed over the cut edge, preventing any further corrosion.
- If installed as per the installation requirements, these edges are adequately drained and ventilated to prevent sitting in pooled water. If the panels are installed incorrectly so that they are subject to pooled water, this may eventually break down the oxide layer and allow for corrosion.
- Movement in the building structure must be accounted for, and allowances included in fixing calculations accordingly.
- Ensure all cut edges have been coated with a suitable sealant.

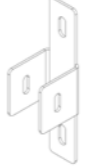
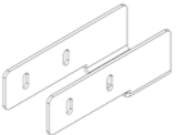
SOLARA ALUMINIUM ACCESSORIES

NAME		DESCRIPTION	USED ON
18 x 50mm Angle		Primary Bracket - Used in Two-piece batten concealed fixing	Two-Piece
U-Bracket		Primary Bracket - Used in single batten U-bracket fixing installations	Single Batten
L Angle		Primary Bracket - Used in end-to-end angle fixing installations and single batten L-angle fixing installations	Single Batten
U Channel		Primary Bracket - Used in end-to-end channel fixing installations	Single Batten
Intermediate Bracket Type A		Intermediate Bracket	Single Batten
Intermediate Bracket Type B		Intermediate Bracket	Single Batten
Flat Plate		Intermediate Bracket	Single Batten

SOLARA ALUMINIUM INSTALLATION GUIDE

TWO-PIECE BATTEN

STANDARD INSTALLATION

1. Position the batten base to the supporting structure and fix it as required.

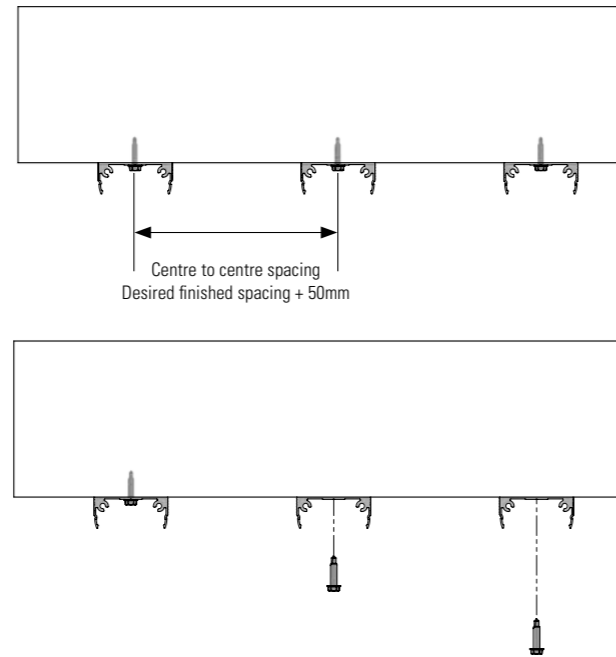
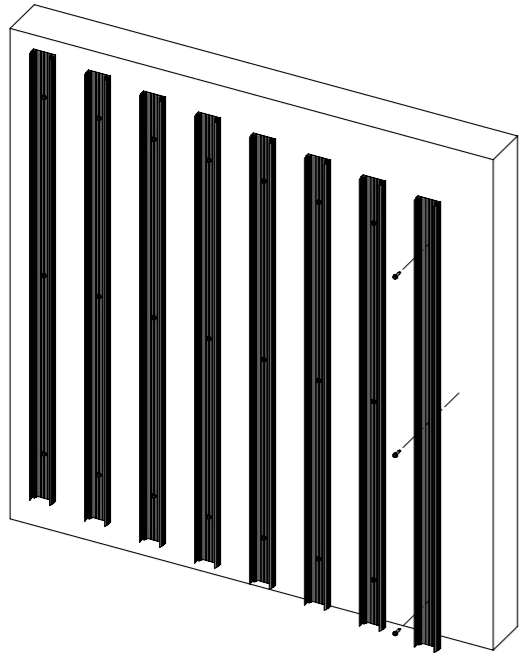

2. Install the batten cover over each of the batten bases, ensuring a tight fit.

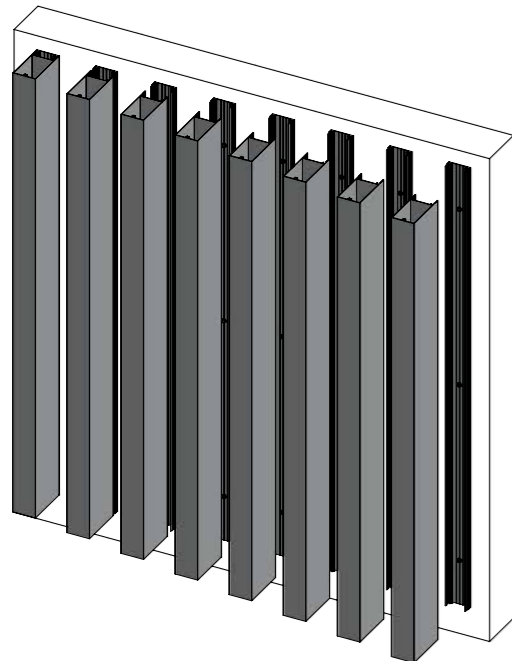

3. Fix the end caps on both ends of the battens using the screws.

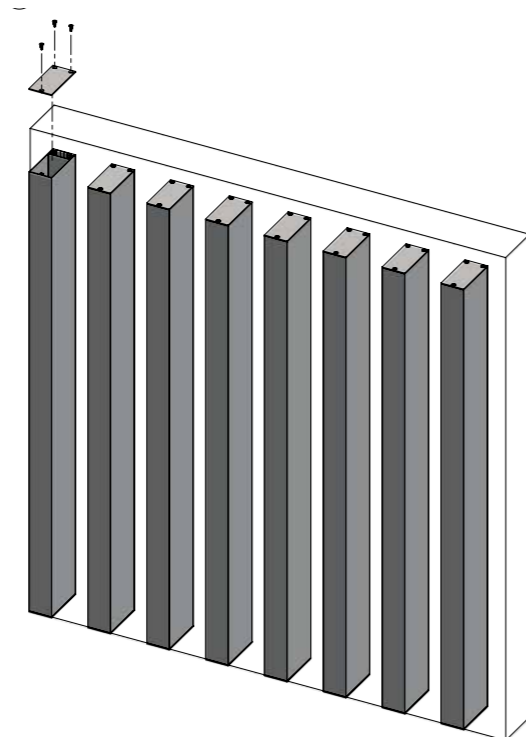

CONCEALED FIXING INSTALLATION

1. Fix the bracket to the supporting structure as required.

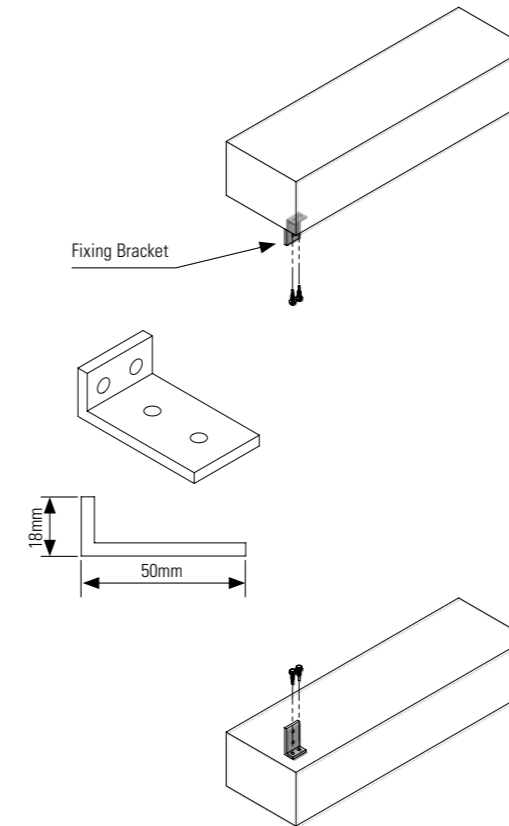

2. Locate and fix the batten cover to the top and bottom brackets.

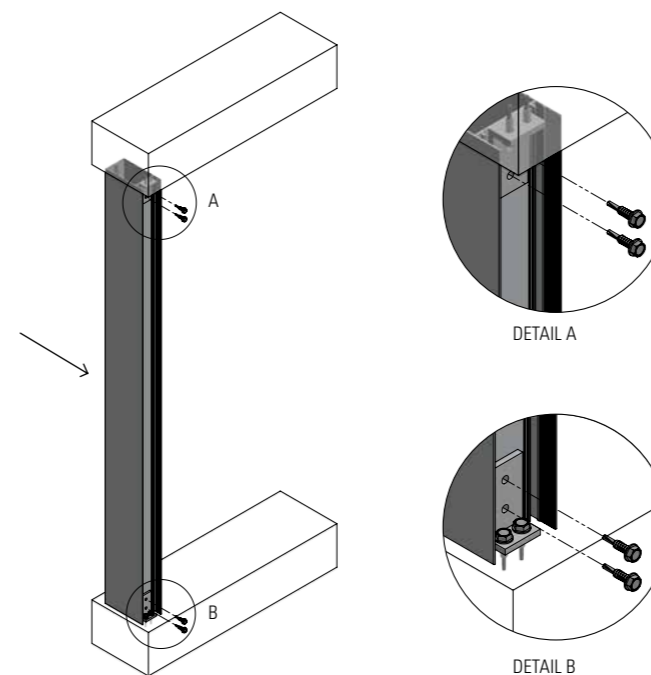

3. Install the batten base.

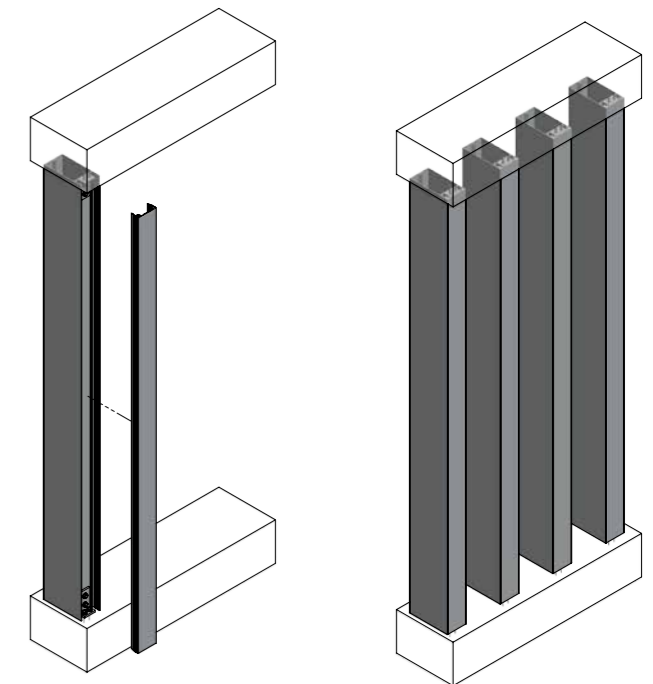

SINGLE BATTEN

L-ANGLE FIXING

1. Fix the angles to the side of the battens.

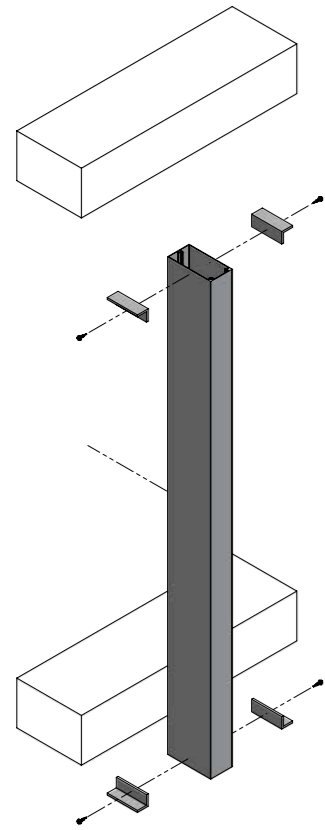

2. Fix the assembly to the supporting structure.

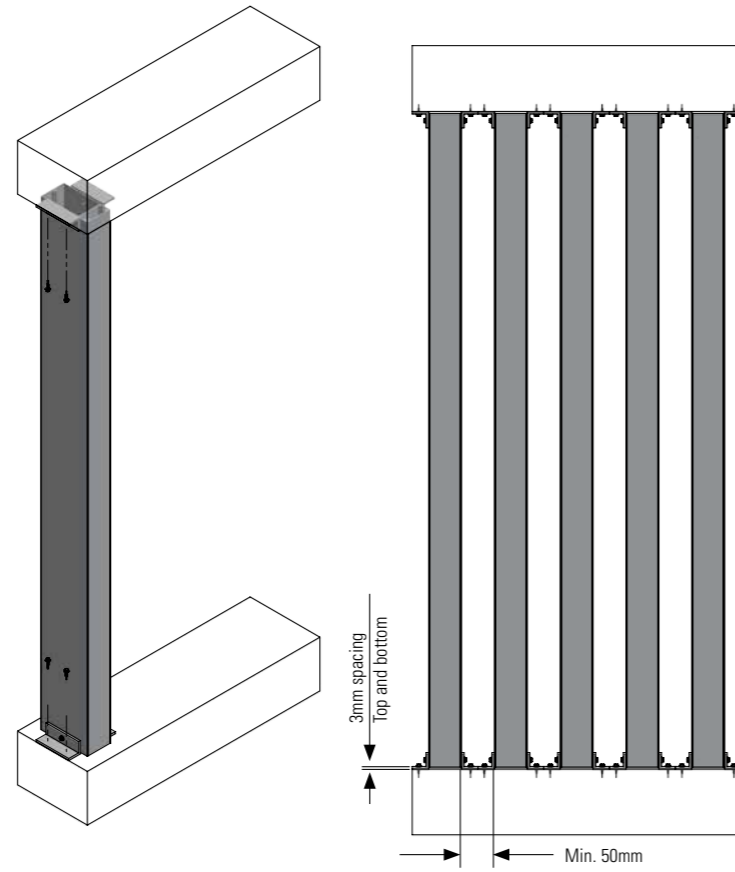

U-BRACKET FIXING

1. Position and fix the U-brackets to the supporting structure.

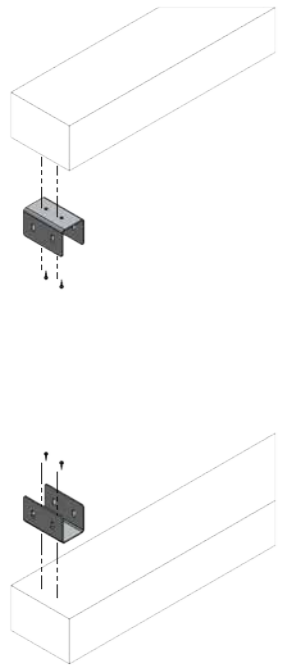

2. Locate and fix the battens on side of the brackets to the supporting structure.

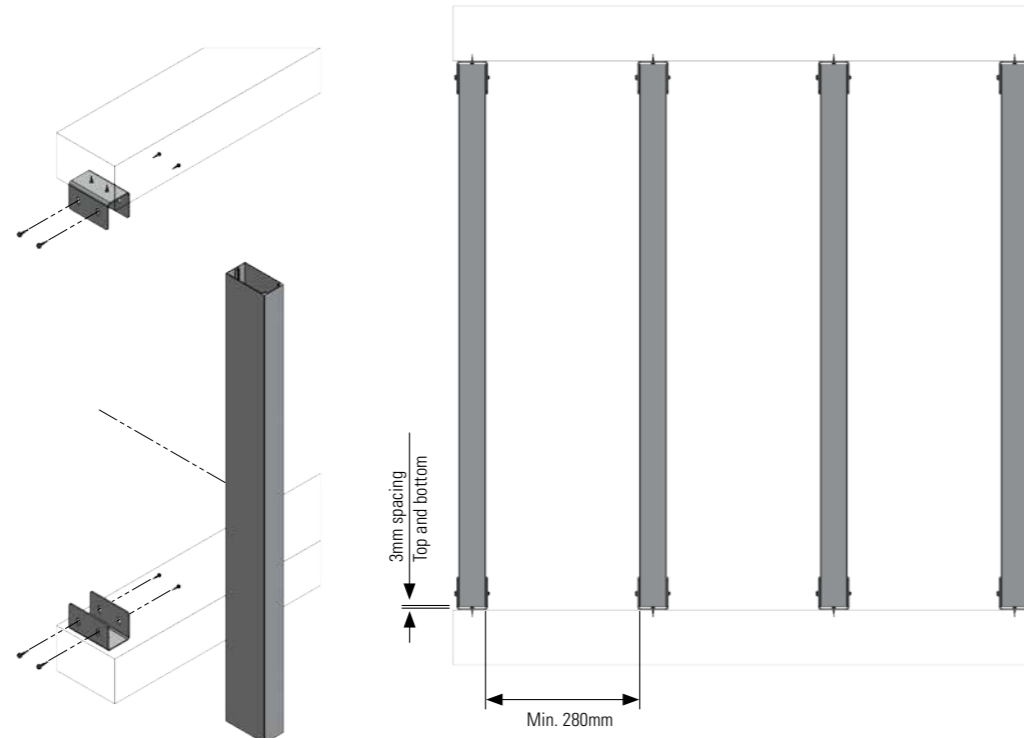

END-TO-END ANGLE FIXING

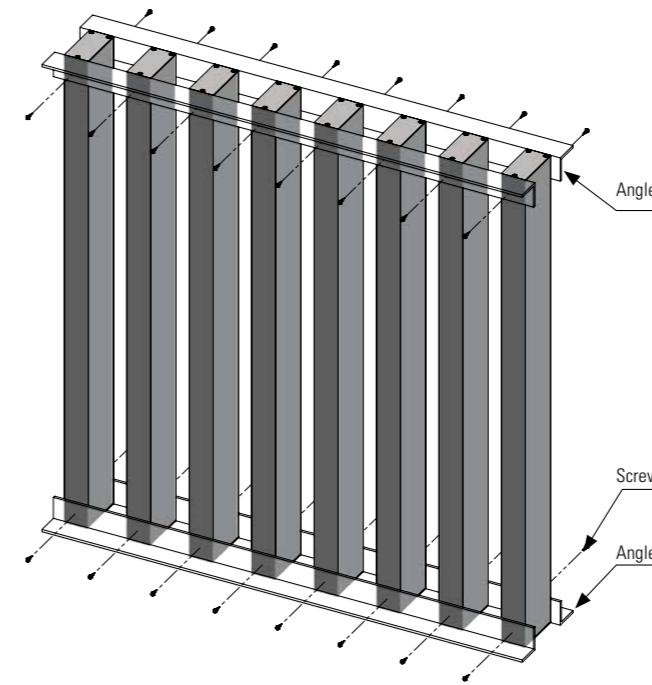

END-TO-END CHANNEL FIXING

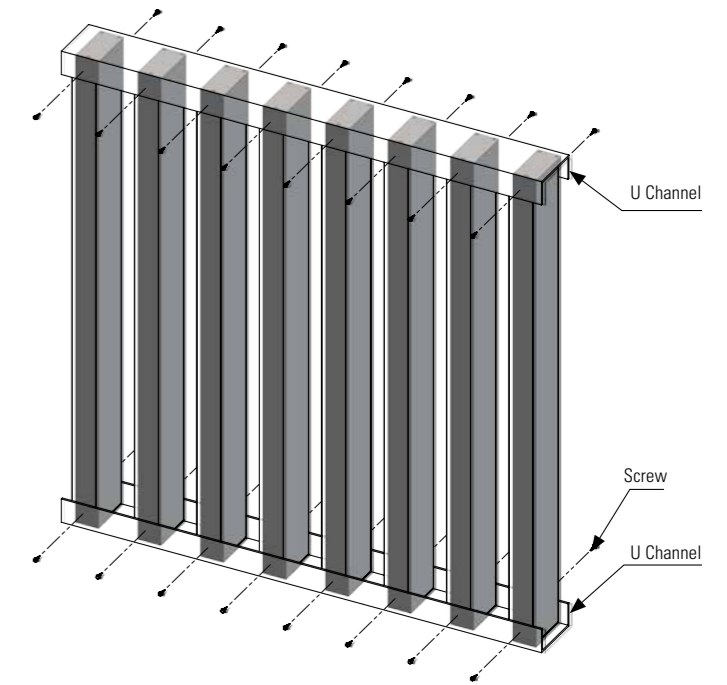

COATING SPECIFICATIONS

POWDER COAT

Solara aluminium is available in the full commercial range of Interpon and Dulux powder coat finishes. These architectural-grade coatings are tested to AAMA2604 and formulated for long-term performance, delivering a super durable thermosetting polyester finish suited to mild, severe and tropical environments. For projects requiring elevated warranty conditions, AAMA2605 ultra durable fluoropolymer finishes can also be specified. Custom powder coat colours are virtually unlimited, and the Fairview team can assist with project specific options.

ANODISED

Solara aluminium can be supplied with an authentic anodised finish, offered in a broad selection of colours. Unlike powder coating, anodising is not a surface coating but a transformation of the aluminium itself, enhancing hardness, durability and weathering performance. As the raw material passes through an electrochemical process, the natural characteristics of the metal are revealed, creating depth, lustre and subtle tonal shifts that change with light and viewing angle.

This natural variation is a defining feature of anodised aluminium and contributes to its architectural appeal. While tonal differences may occur between batches and compared to reference samples, these variations are intentional and help create a truly distinctive façade.

WOODGRAIN

Solara aluminium offers innovative woodgrain options using Interpon's ezy HD2 powder on powder technology, recognised as a market leader in durability. The process begins with a partially cured base layer, followed by a second powder application that forms the woodgrain pattern. Both layers are then cured together to create a single, robust finish with a tactile raised grain that enhances realism.

The result is a highly durable woodgrain surface that outperforms many alternative techniques. Custom woodgrain colours and patterns can be developed on request by contacting the Fairview team.

COATING DATA

POWDER COAT & WOODGRAIN DATA

INTERPON D2525 AAMA2604 RESULTS		
TEST	RESULT	TEST REQUIREMENT
2450	2250	2150
2150	1950	1900
1950	1800	1700
1800	1650	1600
1700	1550	1450
1600	1400	1350
1550	1300	1200
1450	1200	1150
1350	1150	1050
1300	1100	1000
1200	1000	950
1150	950	NA
1100	950	NA

ANNOIDISED DATA

All anodised finishes are supplied in accordance with AS1231 2000 Aluminium and Aluminium Alloys – Anodic Oxidisation Coatings

MATERIAL PROPERTIES

Aluminium material properties in accordance as mentioned the product brochure which is inline with AS/NZS 1664.1:1997 for aluminium alloy 6063 T6.

PROPERTIES	UNITS	VALUES
Alloy		6063
Temper		T6
Standard thickness	mm	1.3 - 3.0
Painted weight	kg/m ²	0.8kg/m ² to 1.6kg/m ²
Raw density	kg/m ³	2700
Young's modulus (E)	GPa	68.3
Tensile strength (25°C)	MPa	220
Yield strength (25°C)	MPa	180
Shear strength	MPa	11
Fatigue strength	MPa	117
Elastic modulus	MPa	69
0.2% proof stress	MPa	>170
Elongation	%	12
Linear thermal expansion		2.4mm/m at 100° temperature difference
Melting range	°C	630–660
Electrical conductivity – Equal vol.	MS/m	32
Electrical conductivity – Equal mass	MS/m	105
Thermal conductivity	W/m-K	201–218

PERFORMANCE

FIRE

As a solid aluminium pre-finished batten, Solara aluminium complies to AS1530.1 and AS1530.3. Powder coat and Woodgrain finishes are compliant to 2022 NCC under clauses C2D10 (5) & C2D10(4)(O).

POWDER COAT & WOODGRAIN FINISHES			
TEST STANDARD	RESULT		
AS1530.1	DEEMED NON-COMBUSTIBLE		
AS1530.3	PASS	Ignitability Index	11
	PASS	Heat Evolved	0
	PASS	Spread of Flame	0
	PASS	Smoke Developed	3
Compliance with C2D10(6)(e)	DEEMED NON-COMBUSTIBLE		

AVERAGE EXPANSION

MATERIAL	CTE(COEFFICIENT OF THERMAL EXPANSION)	ELONGATION PER 1000MM T =50°C
Aluminium battens	23.4	1.17

When installing Solara aluminium please leave the following clearance at each end of a length to allow for unhindered expansion and contraction.

LENGTH	CLEARANCE
≤ 4000mm	5mm
> 4000mm	10mm

Allowance must be made for thermal expansion in the form of oversized holes, with special attention paid in the installation of the material to ensure the screws are not overtightened.

STRUCTURAL DESIGN & SPECIFICATION ASSESSMENT

DESIGN WIND LOADS

The design wind pressure is determined as per AS/NZS 1170.2:2021. The interval recurrence of 1000 years is used for ULS, and 25 years is used for SLS; which relates to Importance Level of 3 and this is typical for Façade application on buildings.

DESIGN MAINTENANCE LOADS

Live loads, taken as incidental maintenance point loads in accordance with good building practice, have been considered based on the expected actions associated with the intended use and occupancy of the structure. A 0.5 kN service point load has been adopted for the battens. A safety factor of 1.5 as per AS1170.0 has been applied to this load.

Rickard Engineering (RE) notes that this might not be applicable to all projects, hence, this is provided separately in chapter 7. If required the results for this incidental load needs to be compared with wind load results and worst case should be considered by the project's engineer.

DESIGN SPAN TABLE - TWO-PIECE BATTEN SYSTEM

The following pages include tables showing the maximum span under wind loads, considering both:

- Ultimate wind pressure, where the strength/stress of the section has been checked, and
- Serviceability wind pressure, where the deflection of the section has been checked.

Additionally, the tables present the maximum span for resisting an incidental load of 0.5 kN. For more details about this load case, please refer to the maintenance/incidental load (Q) section.

The figures shown in the maximum span columns represent the governing values, considering both the deflection limit and the stress/strength limit.

Also referring to deflection limits, we have prepared two sets of tables which both limit are used in the industry, L/90 and L/250.

BATTEN 50 MM X 25 MM

SPAN TABLE (STRONG AXIS)

Note: The section is stronger about the Y–Y axis and weaker about the X–X axis; therefore, the span table presented in Section 6.1.1 is for weak axis and governs the batten design.

SPAN TABLE (WEAK AXIS)

DESIGNATION	MASS PER M	50X25 BATTEN MAX SPAN TABLE – AXIS [X-X] – H/90			
		DESIGN WIND PRESSURE WU [KPA]	DESIGN WIND PRESSURE WS [KPA]	MAXIMUM BATTEN SPAN (MM)	
50 X 25MM	KG/M			WIND	Q = LIVE LOAD
	1.013 kg/m	1	0.65	1900	500
		1.5	0.97	1650	
		2	1.29	1500	
		2.5	1.62	1400	
		3	1.94	1300	
		3.5	2.26	1250	
		4	2.59	1200	
		4.5	2.91	1150	
5	3.23	1100			
6	3.88	1050			
7	4.53	1000			
8	5.18	900			

Table: Design Span table [Span/90]

DESIGNATION	MASS PER M	50X25 BATTEN MAX SPAN TABLE – AXIS [X-X] – H/250			
		DESIGN WIND PRESSURE WU [KPA]	DESIGN WIND PRESSURE WS [KPA]	MAXIMUM BATTEN SPAN (MM)	
50 X 25MM	KG/M			WIND	Q = LIVE LOAD
	1.013 kg/m	1	0.65	1350	300
		1.5	0.97	1200	
		2	1.29	1050	
		2.5	1.62	1000	
		3	1.94	950	
		3.5	2.26	900	
		4	2.59	860	
		4.5	2.91	835	
5	3.23	800			
6	3.88	750			
7	4.53	700			
8	5.18	650			

Table: Design Span table [Span/250]

Notes:

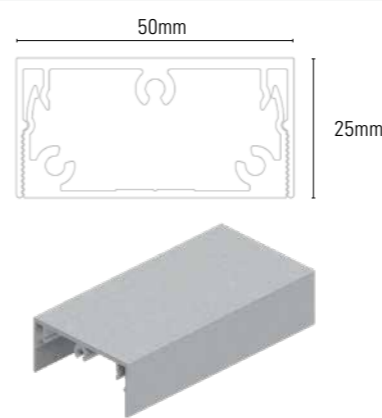
1. The batten is designed using 6063-T6 aluminium alloy.
2. "Q" represents the incidental/maintenance live load of 0.5 kN for serviceability checks and 0.75 kN (1.5 live load factor) for ultimate strength design.
3. The design assumes a simply supported batten with a single span. Any multiple-span condition must be checked independently by the engineer and results can be improved accordingly.
4. The buckling design of the aluminium battens is in accordance with AS/NZS 1664.1.
5. Span limits are based on ULS stress and SLS deflection criteria for the batten design in the x- axis, with SLS deflection limits of span/250 and span/90 for wind and maintenance loads. Depending on project requirements, engineer must assess the governing case for the project and determine whether wind loads, maintenance loads, or both govern the batten design.
6. Fixings, connections, and support frames are to be checked independently.
7. The span tables are provided for general guidance only. A qualified structural engineer must assess the suitability and structural adequacy of the batten for each specific project.

BATTEN 50 MM X 100 MM

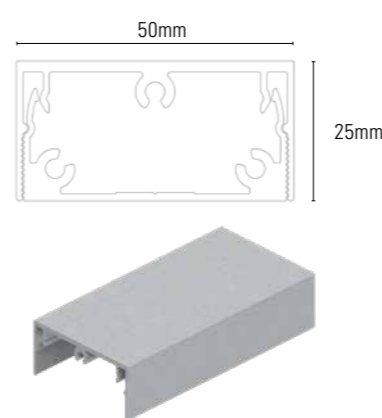
SPAN TABLE (STRONG AXIS)

DESIGNATION	MASS PER M	50X100 BATTEN MAX SPAN TABLE - STRONG AXIS [X-X] - H/90			
		DESIGN WIND PRESSURE WU [KPA]	DESIGN WIND PRESSURE WS [KPA]	MAXIMUM BATTEN SPAN (MM)	
50 X 100MM	KG/M			WIND	Q = LIVE LOAD
	1.6376 kg/m	1	0.65	9300	5700
		1.5	0.97	8400	
		2	1.29	7500	
		2.5	1.62	6900	
		3	1.94	6600	
		3.5	2.26	6300	
		4	2.59	6000	
		4.5	2.91	5800	
		5	3.23	5600	
6	3.88	5250			
7	4.53	4800			
8	5.18	4500			

Table: Design Span table [Span/90]

DESIGNATION	MASS PER M	50X100 BATTEN MAX SPAN TABLE - STRONG AXIS [X-X] - H/250			
		DESIGN WIND PRESSURE WU [KPA]	DESIGN WIND PRESSURE WS [KPA]	MAXIMUM BATTEN SPAN (MM)	
50 X 100MM	KG/M			WIND	Q = LIVE LOAD
	1.6376 kg/m	1	0.65	5400	3600
		1.5	0.97	4500	
		2	1.29	4200	
		2.5	1.62	3900	
		3	1.94	3750	
		3.5	2.26	3600	
		4	2.59	3350	
		4.5	2.91	3200	
		5	3.23	3150	
6	3.88	3000			
7	4.53	2850			
8	5.18	2700			

Table: Design Span table [Span/90]

BATTEN 50 MM X 100 MM

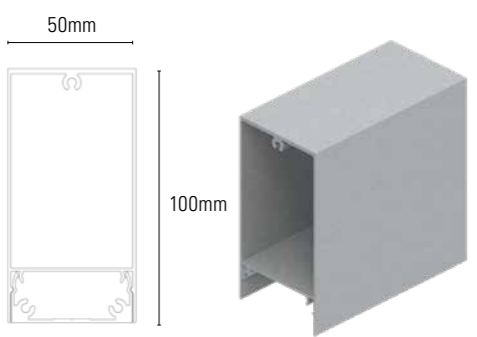
SPAN TABLE (WEAK AXIS)

DESIGNATION	MASS PER M	50X100 BATTEN MAX SPAN TABLE - WEAK AXIS [Y-Y] - H/90			
		DESIGN WIND PRESSURE WU [KPA]	DESIGN WIND PRESSURE WS [KPA]	MAXIMUM BATTEN SPAN (MM)	
50 X 100MM	KG/M			WIND	Q = LIVE LOAD
	1.6376 kg/m	1	0.65	5400	3600
		1.5	0.97	4500	
		2	1.29	4299	
		2.5	1.62	3900	
		3	1.94	3600	
		3.5	2.26	3500	
		4	2.59	3400	
		4.5	2.91	3200	
		5	3.23	3150	
6	3.88	2950			
7	4.53	2800			
8	5.18	2700			

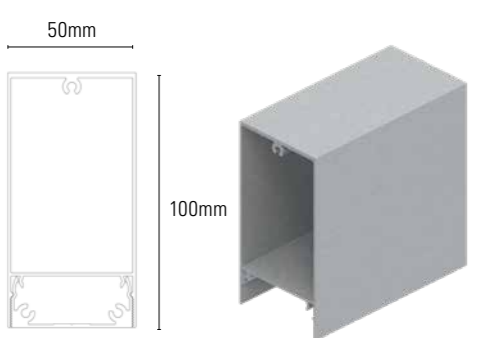
Table: Design Span table [Span/90]

DESIGNATION	MASS PER M	50X100 BATTEN MAX SPAN TABLE - WEAK AXIS [Y-Y] - H/250			
		DESIGN WIND PRESSURE WU [KPA]	DESIGN WIND PRESSURE WS [KPA]	MAXIMUM BATTEN SPAN (MM)	
50 X 100MM	KG/M			WIND	Q = LIVE LOAD
	1.6376 kg/m	1	0.65	3600	2100
		1.5	0.97	3300	
		2	1.29	3050	
		2.5	1.62	2850	
		3	1.94	2100	
		3.5	2.26	2500	
		4	2.59	2430	
		4.5	2.91	2300	
		5	3.23	2250	
6	3.88	2100			
7	4.53	2000			
8	5.18	1900			

Table: Design Span table [Span/90]

Notes:

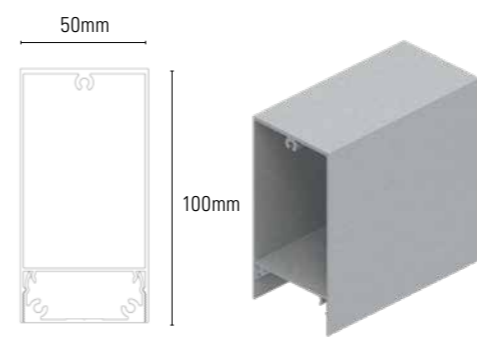
- The batten is designed using 6063-T6 aluminium alloy.
- "Q" represents the incidental/maintenance live load of 0.5 kN for serviceability checks and 0.75 kN (1.5 live load factor) for ultimate strength design.
- The design assumes a simply supported batten with a single span. Any multiple-span condition must be checked independently by the engineer and results can be improved accordingly.
- The buckling design of the aluminium battens is in accordance with AS/NZS 1664.1.
- Span limits are based on ULS stress and SLS deflection criteria for the batten design in the x- axis, with SLS deflection limits of span/250 and span/90 for wind and maintenance loads. Depending on project requirements, engineer must assess the governing case for the project and determine whether wind loads, maintenance loads, or both govern the batten design.
- Fixings, connections, and support frames are to be checked independently.
- The span tables are provided for general guidance only. A qualified structural engineer must assess the suitability and structural adequacy of the batten for each specific project.

BATTEN 50 MM X 200 MM

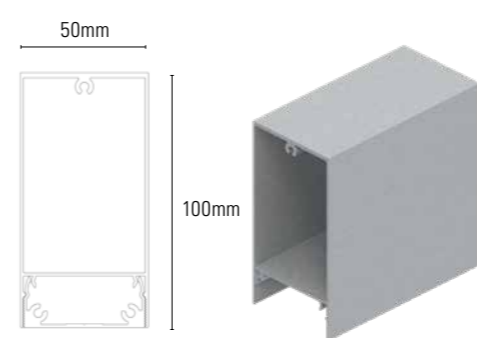
SPAN TABLE (STRONG AXIS)

DESIGNATION	MASS PER M	50X200 BATTEN MAX SPAN TABLE - STRONG AXIS [X-X] - H/90			
		DESIGN WIND PRESSURE WU [KPA]	DESIGN WIND PRESSURE WS [KPA]	MAXIMUM BATTEN SPAN (MM)	
50 X 200MM	KG/M			WIND	Q = LIVE LOAD
	3.14 kg/m	1	0.65	19500	17400
		1.5	0.97	17100	
		2	1.29	15600	
		2.5	1.62	14400	
		3	1.94	13500	
		3.5	2.26	12900	
		4	2.59	12300	
		4.5	2.91	11700	
5	3.23	11400			
6	3.88	10800			
7	4.53	10200			
8	5.18	9600			

Table: Design Span table [Span/90]

DESIGNATION	MASS PER M	50X200 BATTEN MAX SPAN TABLE - STRONG AXIS [X-X] - H/250			
		DESIGN WIND PRESSURE WU [KPA]	DESIGN WIND PRESSURE WS [KPA]	MAXIMUM BATTEN SPAN (MM)	
50 X 200MM	KG/M			WIND	Q = LIVE LOAD
	3.14 kg/m	1	0.65	13800	3600
		1.5	0.97	12000	
		2	1.29	11100	
		2.5	1.62	10200	
		3	1.94	9600	
		3.5	2.26	9000	
		4	2.59	8700	
		4.5	2.91	8400	
5	3.23	8100			
6	3.88	7500			
7	4.53	7200			
8	5.18	6900			

Table: Design Span table [Span/90]

BATTEN 50 MM X 200 MM

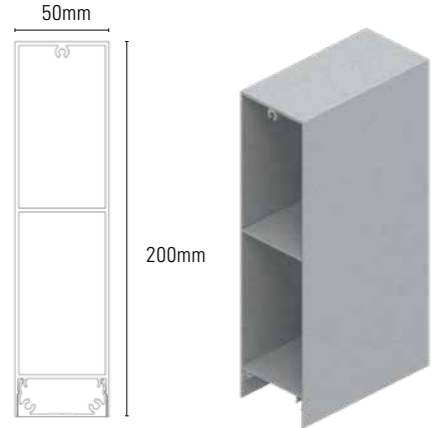
SPAN TABLE (WEAK AXIS)

DESIGNATION	MASS PER M	50X200 BATTEN MAX SPAN TABLE - WEAK AXIS [Y-Y] - H/90			
		DESIGN WIND PRESSURE WU [KPA]	DESIGN WIND PRESSURE WS [KPA]	MAXIMUM BATTEN SPAN (MM)	
50 X 200MM	KG/M			WIND	Q = LIVE LOAD
	3.14 kg/m	1	0.65	6000	6000
		1.5	0.97	5100	
		2	1.29	4800	
		2.5	1.62	4500	
		3	1.94	4200	
		3.5	2.26	3900	
		4	2.59	3800	
		4.5	2.91	3600	
5	3.23	3500			
6	3.88	3350			
7	4.53	3150			
8	5.18	3000			

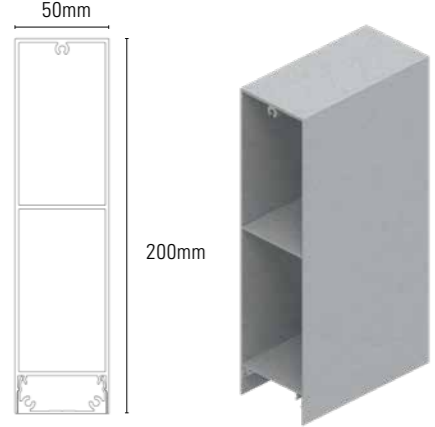
Table: Design Span table [Span/90]

DESIGNATION	MASS PER M	50X200 BATTEN MAX SPAN TABLE - WEAK AXIS [Y-Y] - H/250			
		DESIGN WIND PRESSURE WU [KPA]	DESIGN WIND PRESSURE WS [KPA]	MAXIMUM BATTEN SPAN (MM)	
50 X 200MM	KG/M			WIND	Q = LIVE LOAD
	3.14 kg/m	1	0.65	6900	3600
		1.5	0.97	6000	
		2	1.29	5400	
		2.5	1.62	4800	
		3	1.94	4700	
		3.5	2.26	4350	
		4	2.59	4350	
		4.5	2.91	4150	
5	3.23	3900			
6	3.88	3750			
7	4.53	3600			
8	5.18	3300			

Table: Design Span table [Span/90]

Notes:

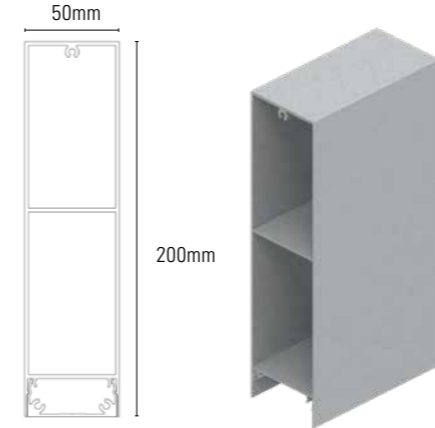
1. The batten is designed using 6063-T6 aluminium alloy.
2. "Q" represents the incidental/maintenance live load of 0.5 kN for serviceability checks and 0.75 kN (1.5 live load factor) for ultimate strength design.
3. The design assumes a simply supported batten with a single span. Any multiple-span condition must be checked independently by the engineer and results can be improved accordingly.
4. The buckling design of the aluminium battens is in accordance with AS/NZS 1664.1.
5. Span limits are based on ULS stress and SLS deflection criteria for the batten design in both axes (strong & weak), with SLS deflection limits of span/250 and span/90 for wind and maintenance loads. Depending on project requirements, engineer must assess the governing case for the project and determine whether wind loads, maintenance loads, or both govern the batten design.
6. Fixings, connections, and support frames are to be checked independently.
7. The span tables are provided for general guidance only. A qualified structural engineer must assess the suitability and structural adequacy of the batten for each specific project.

MAINTENANCE/INCIDENTAL LOAD (Q)

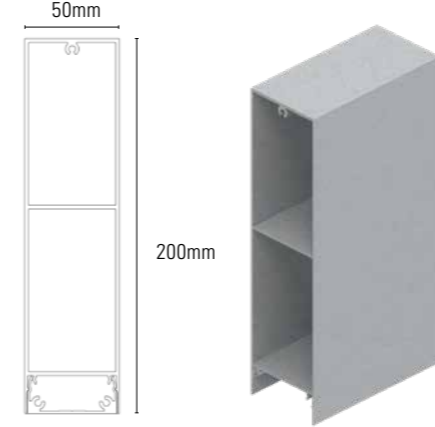
Below are the tables presenting the batten design calculations for maintenance/incidental loads for three different batten system types, considering both strong- and weak-axis, based on deflection limits of span/90 and span/250. A 0.5 kN service maintenance/incidental load has been considered, with the corresponding ultimate load taken as $1.5 \times 0.5 \text{ kN} = 0.75 \text{ kN}$ for ultimate strength design.

The objective of this section is to present the calculation process for the batten design checks for both ultimate and serviceability limit states.

Further to above and below diagram, it should also be noted that live load on the minor axis is only possible/applicable at the first or last batten if it is exposed. In some cases, due to the architectural design of the batten screen and the geometry of surrounding elements, this condition may not apply.

Also, depending on the project requirements, the deflection check may not need to be considered.

Please note that the results below are based solely on the Live Load (Q) and do not include any other load cases such as wind loading.

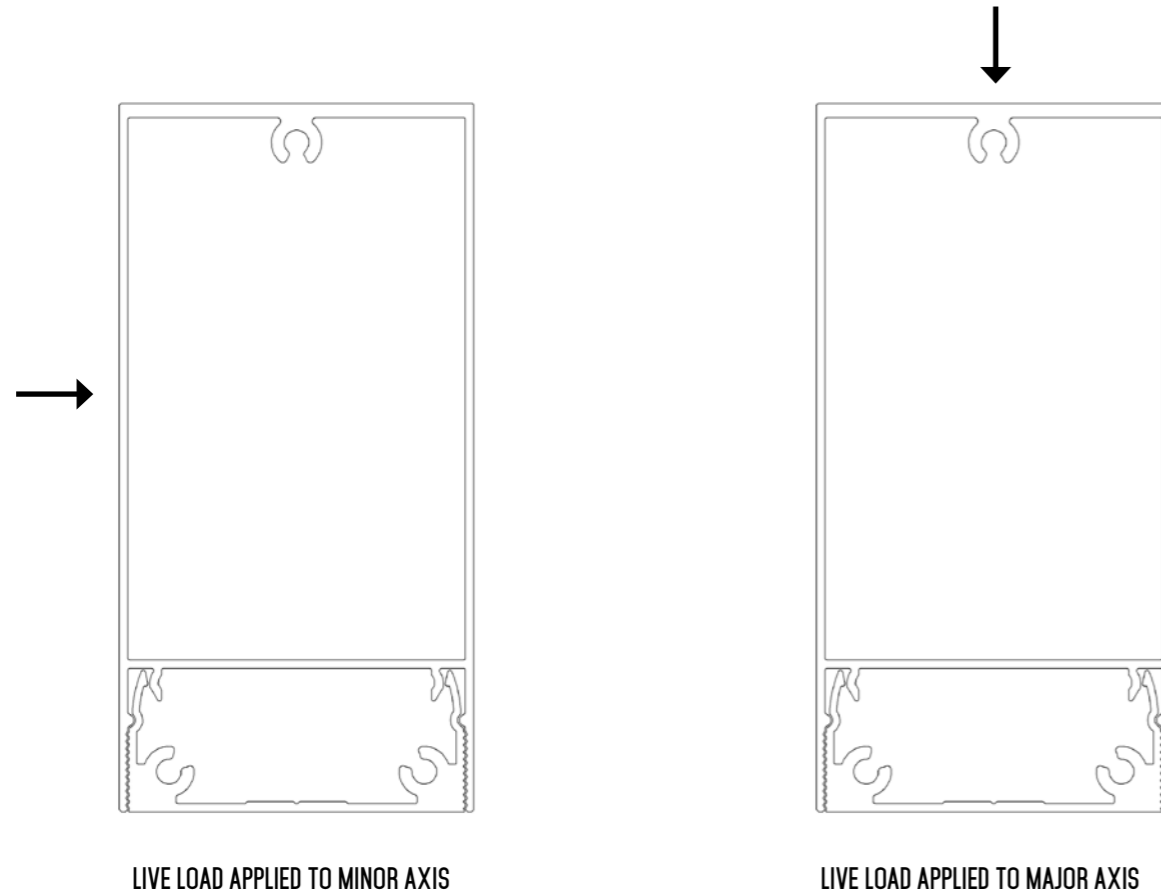

The tables below present the capacity values considering two deflection limits, as recommended in the design span tables (L/90 and L/250).

The stress/strength limit table provides limits based solely on strength capacity, without consideration of deflection, as deflection may be ignored or relaxed depending on specific project requirements.

DEFLECTION LIMIT – SPAN/90

BATTEN DESIGN FOR MAINTENANCE/INCIDENTAL LOAD [Q=0.5KN]								
DEFLECTION. [H/250]								
DESIGNATION	AXIS	MAXIMUM SPAN. H [M] ¹	STRESS [N/MM ²]	MEMBER BUCKLING CAPACITY FC= N/MM ² ²	STRESS RATIO = STRESS / CAPACITY	DEFLECTION Δ [MM]	DEFLECTION LIMIT Δ LIMIT [MM]	STRESS RATIO = STRESS / CAPACITY
50x25 Batten	Weak Axis	0.3	64.48	209.95	0.31	1.02	1.20	0.85
50x100 Batten	Strong Axis	3.6	79.59	138.06	0.58	14.10	14.40	0.98
	Weak Axis	2.1	56.58	143.15	0.40	7.90	8.40	0.94
50x200 Batten	Strong Axis	10.5	50.24	117.40	0.43	41.70	42.00	0.99
	Weak Axis	3.6	33.92	145.08	0.23	13.96	14.40	0.97

DEFLECTION LIMIT – SPAN/250

BATTEN DESIGN FOR MAINTENANCE/INCIDENTAL LOAD [Q=0.5KN]								
DEFLECTION. [H/250]								
DESIGNATION	AXIS	MAXIMUM SPAN. H [M] ¹	STRESS [N/MM ²]	MEMBER BUCKLING CAPACITY FC= N/MM ² ²	STRESS RATIO = STRESS / CAPACITY	DEFLECTION Δ [MM]	DEFLECTION LIMIT Δ LIMIT [MM]	STRESS RATIO = STRESS / CAPACITY
50x25 Batten	Weak Axis	0.3	64.48	209.95	0.31	1.02	1.20	0.85
50x100 Batten	Strong Axis	3.6	79.59	138.06	0.58	14.10	14.40	0.98
	Weak Axis	2.1	56.58	143.15	0.40	7.90	8.40	0.94
50x200 Batten	Strong Axis	10.5	50.24	117.40	0.43	41.70	42.00	0.99
	Weak Axis	3.6	33.92	145.08	0.23	13.96	14.40	0.97

- 1 The maximum span is taken from the design span tables for the maintenance load "Q".
- 2 The buckling capacity of the member is determined as per AS/NZS 1664.1 and clause 3.4.15.

Notes:

1. The batten is designed using 6063-T6 aluminium alloy.
2. "Q" represents the incidental/maintenance live load of 0.5 kN for serviceability checks and 0.75 kN (1.5 live load factor) for ultimate strength design.
3. The design assumes a simply supported batten with a single span. Any multiple-span condition must be checked independently by the engineer and results can be improved accordingly.
4. The buckling design of the aluminium battens is in accordance with AS/NZS 1664.1.
5. Span limits are based on ULS stress and SLS deflection criteria for the batten design in both axes (strong & weak), with SLS deflection limits of span/250 and span/90 for wind and maintenance loads. Depending on project requirements, engineer must assess the governing case for the project and determine whether wind loads, maintenance loads, or both govern the batten design.
6. Fixings, connections, and support frames are to be checked independently.
7. The span tables are provided for general guidance only. A qualified structural engineer must assess the suitability and structural adequacy of the batten for each specific project.

STRESS/STRENGTH LIMIT

BATTEN DESIGN FOR MAINTENANCE/INCIDENTAL LOAD [Q=0.5KN]					
DEFLECTION, [H/250]					
DESIGNATION	AXIS	MAXIMUM SPAN, H [M] ¹	STRESS [N/MM ²]	MEMBER BUCKLING CAPACITY FC= N/MM ² ²	STRESS RATIO = STRESS / CAPACITY
50x25 Batten	Weak Axis	0.88	189.15	209.95	0.90
50x100 Batten	Strong Axis	5.7	126.02	132.48	0.95
	Weak Axis	4.5	121.25	135.24	0.90
50x200 Batten	Strong Axis	19.5	93.30	102.70	0.91
	Weak Axis	11.2	105.54	116.40	0.91

Please note that the above table is prepared solely to assess the section capacity under a live load (Q) of 0.5 kN. The values shown should be compared with the relevant wind pressures presented in the design span tables to ensure compliance with overall design requirements.

COMPLIANCE

NCC/BCA 2022 AMENDMENT 2

The National Construction Code (NCC) 2022 sets the minimum standards for building safety, performance, and quality in Australia. For the Fairview Aluminium battens, compliance with the NCC ensures that the battens perform safely and effectively as part of the building façade. Key areas considered include:

CATEGORY	NCC / STANDARD REFERENCE	COMMENTS
Structural	NCC 2022 Volume One Part B– Structural Provisions, AS 1170.2	This report provides the NCC compliance for structural performance.
Fire	"AS 1530.1 – Non-combustibility AS 1530.3 – Spread of Flame and Smoke Development NCC C2D10(6)(e) (formerly C1.9), where applicable"	"As per clause C2D10 (6), extrusions are solid aluminium and identified as a material that satisfies AS 1530.1 when supplied as a solid metal product (not composite). AS1530.3; Solid aluminium is a metal, and metals do not meaningfully ignite, propagate flame, release heat, or produce smoke when exposed to fire because they do not contain combustible constituents."
Weatherproofing	NCC Volume One – Weatherproofing clause F3P1	F3P1 requires that external walls and attached elements prevent water penetration that could cause dampness, unhealthy conditions, or material deterioration. The aluminium privacy screen is not part of the primary weatherproofing system and is designed/installed so it does not redirect water into the wall. When installed in accordance with AS 1562.1 for metal cladding, the screen does not compromise the wall's compliance with F3P1.

WARRANTY

The Solara Sunscreen system is sustainable and incredibly durable when used in the right application and installed by licensed professionals. Solara includes a 15-year warranty, subject to standard terms and conditions.

DISCLAIMER

While the information provided relating to Solara Sunscreen products is true to the tests and measures available to us, the information contained in this document is general in nature only and does not constitute project-specific building, construction, or fire-safety advice. Before acting on any information in this document, you should carefully consider its appropriateness in relation to your project parameters and requirements.

Solara is deemed suitable or compliant only after approval from building and construction professionals associated with the specific project or development. If you'd like further insight about this topic, contact our team on 1800 007 175 or email helpdesk@fv.com.au. We're here to help.

For more information on the Solara Sunscreen range and to order online samples, visit www.fv.com.au or call 1800 007 175.

You'll also find helpful resources detailing:

- Product guides and specifications
- Installation recommendations
- Maintenance and compliance information
- All architectural details
- Finishing options and colour swatches
- Solara technical data
- Solara maintenance info
- Warranty information
- Contact information

All colours represented in all imagery have been reproduced as a guide only. For precise colour reproduction please refer to physical product samples.

This brochure has been designed and printed in Australia.



FAIRVIEW™

DEFINING ARCHITECTURE SINCE 1988



SALES ENQUIRIES 1800 007 175

SALES@FV.COM.AU

FV.COM.AU

SOLARA / MAY 2026